



Vorne Industries

87/232
Serial Display
User's Manual

Chapter 1	Setting Up Your Display For Operation	3
1.1	Accessing Wiring Connections And Selection Switches	3
1.2	Setting The DIP Switches For Your Application	3
	Run and Program Modes	3
	DIP Switch Settings	4
	Baud Rate	4
	Data Bits	4
	Terminator	4
	Communication Protocol And Address	5
1.3	Connecting Power To The Display	6
1.4	Basic Information About Serial Communication Ports	6
1.5	RS-232 Communication To A Single Display	7
	Selecting RS-232 Communication	7
	RS-232 Connectors	7
	Wiring Diagram For An RS-232 Host Device To One Display	8
	Guidelines For Wiring RS-232 Devices	8
1.6	RS-422 Or RS-485 Communication To One Or More Displays	8
	Selecting RS-422/RS-485 Communication	8
	RS-422/RS-485 Connectors	9
	Wiring Diagram For An RS-422 Or RS-485 Host Device To One Display	9
	Wiring Diagram For An RS-422 Or RS-485 Host Device To More Than One Display	9
	Guidelines For Wiring RS-422 Or RS-485 Devices	10
1.7	RS-232 Communication To More Than One Display	11
1.8	Understanding The General Display Format	11
Chapter 2	Using Terminator Only Protocol	12
2.1	Terminator Only Protocol Communication Format	12
Chapter 3	Using The Simple Packet Protocol	12
3.1	Simple Packet Communication Format	12
3.2	Simple Packet Commands	14
	Display Data	14
	Flash Data	14
	Change Color (For Tri-color Display's)	15

Activate Relay	15
3.3 Addressing Multiple Displays	16
Unit Address	16
3.4 Using Checksums And Command Acknowledgments	17
Chapter 4 Advanced Features Of the 87/232 Display	18
4.1 VDP4 Options	18
Baud Rate	18
Data Bits	18
Display Justification	18
Leading Zeroes	18
Fixed Decimal Point After Digit	18
Number of Display Digits	19
Header	19
Terminator	19
Checksum	19
Command Acknowledgment	19
Unit Address	19
Member of Group(s)	19
Relay Setup	19
Selecting A Communication Protocol	20
Appendix A Operating Specifications	21
Appendix B Character Set Listing	22
Appendix C Display Dimensions	23

Notice Of Disclaimer

While the information in this manual has been carefully reviewed for accuracy, Vorne Industries, Inc. assumes no liability for any errors, or omissions in the information. Vorne Industries also reserves the right to make changes without further notice to any products described in this manual.

Chapter 1 Setting Up Your Display For Operation

This chapter describes how to set up the display hardware for operation, including setting the dip switches, connecting power, and wiring to the serial communication port. There are many references in this chapter to the term **host device**. Simply stated, the host device is whatever device will be sending serial data to the 87/232 display. Some typical host devices are PLC BASIC modules, computers, scales, master clock systems, panel meters, etc.

1.1 Accessing Wiring Connections And Selection Switches

All external power and communication line connections to the display are made to printed circuit board mounted terminal strips. These terminal strips, as well as a 10 position DIP switch, and COM PORT selection switch, can be accessed by removing the back panel user access plate.



WARNING - SHOCK HAZARD

Always completely disconnect power from the display before opening the user access plate. Do not reapply power to the display until the access plate has been reinstalled and securely closed.

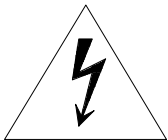

There are two 7/8" conduit openings on the back panel of the display, provided for bringing external wiring into the display enclosure. If these conduit openings will not be used for wiring, these openings can be filled with plastic plugs (Caplugs Part Number BP-7/8) which are provided with the display.

The left most conduit opening is provided for power wiring, the right most for signal wiring. **It is not recommended to run power wiring and signal wiring in the same conduit!**

1.2 Setting The DIP Switches For Your Application

Note: Changes to the DIP switches are only acknowledged at power up. Factory default settings are shown in gray.

Run and Program Modes

1	Mode
ON	Program
OFF	Run

For normal operation the Run/Program switch should be set to Run (off). Setting the unit to Program mode allows the unit to be customized using VDP4 and to run one of two diagnostic routines. If DIP switch 2 is off, the display cycles thru the following display diagnostic.

- a. Error status Should show E0. E1 or E2 indicates a memory error.
- b. Unit Address Default value is 00. This will not match the DIP switch address.
- c. Red segment test The unit will turn on 1 segment at a time A thru F and DP.

d. Green segment test. For a single color display a blank screen will be displayed.

e. All segments ON.

f. Unit type. 1 = 87/232

g. --. This is a separator between the Unit type and the Software version.

h. Software version. This number is displayed on two consecutive screens (Ex: 1.1.3).

If DIP switch 2 is on, the display runs a DIP switch diagnostic. This diagnostic displays the HEX value of DIP switches 3 thru 10. (switches 3 to 6 = MSD, switches 7 to 10 = LSD)

DIP Switch Settings

For normal operation the Settings DIP switch should be set to DIP switch (on).

In program mode, Switch 2 selects between Display test (off) and DIP switch test (on).

2	Settings
ON	DIP Switch
OFF	VDP4

Baud Rate

The **baud rate** of your 87 series display determines how fast serial data will be communicated to the display. In all cases this setting must match the baud rate of the device that will be sending serial data to the display (the host device).

3	4	Baud Rate
OFF	OFF	300
OFF	ON	1,200
ON	OFF	9,600
ON	ON	19,200

Data Bits

The number of Data Bits selected must match the number of data bits transmitted by the host.

5	Data Bits
ON	8
OFF	7

Terminator

The Terminator selection specifies which character ends the transmission. In cases where the host device transmits a <CR><LF> combination as the terminator, select <CR>.

6	Terminator
ON	<LF>
OFF	<CR>

Communication Protocol And Address

The first communication protocol is **Terminator Only**. This is for applications where you can control the data being transmitted to the display, and wish to use the very simplest form of communication possible. We define this simplest form of communication as sending the data to be displayed, followed by a carriage return or line feed character. If this seems to be the best communication protocol for your application, refer to Chapter 2 Using Terminator Only Protocol.

To select Terminator Only protocol, set DIP switches 7, 8, 9, and 10 to the ON position.

The second communication protocol is the **Simple Packet** protocol. This is for applications where you can control the data being transmitted to the display, but where you would like to access some advanced features. These features include independently addressing multiple displays, sending an optional checksum to validate the data, receiving an optional acknowledgment from the display to verify the receipt of data, flashing the display, or controlling an optional relay in the display. If this seems to be the best communication protocol for your application, please refer to Chapter 3 Using The Simple Packet Protocol.

7	8	9	10	Address	Protocol
OFF	OFF	OFF	OFF	0	Simple Packet
OFF	OFF	OFF	ON	1	Simple Packet
OFF	OFF	ON	OFF	2	Simple Packet
OFF	OFF	ON	ON	3	Simple Packet
OFF	ON	OFF	OFF	4	Simple Packet
OFF	ON	OFF	ON	5	Simple Packet
OFF	ON	ON	OFF	6	Simple Packet
OFF	ON	ON	ON	7	Simple Packet
ON	OFF	OFF	OFF	8	Simple Packet
ON	OFF	OFF	ON	9	Simple Packet
ON	OFF	ON	OFF	10	Simple Packet
ON	OFF	ON	ON	11	Simple Packet
ON	ON	OFF	OFF	12	Simple Packet
ON	ON	OFF	ON	13	Simple Packet
ON	ON	ON	OFF	14	Simple Packet
ON	ON	ON	ON	None	Terminator Only

1.3 Connecting Power To The Display

Power connections are made to the three pin POWER terminal strip (marked P1). Connect power to this terminal strip as shown below.

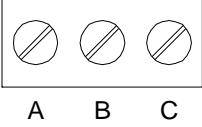
3 Pin POWER Terminal Strip (P1)	Pin	120 VAC Powered Units	12 VDC Powered Units
	A	120 VAC (Hot)	+ 12 VDC
	B	120 VAC (Neutral)	DC Ground
	C	Earth Ground	Earth Ground

Proper grounding is an important aspect of power wiring, both as a safety measure and for improved electrical noise immunity. **Always** connect Earth Ground to the 87/232 display.



WARNING

Terminal C (Earth Ground) must always be connected to a reliable low impedance earth ground. This provides a safety ground to the enclosure, as well as a return path for electrical noise.

The power requirements for all standard 87/232 display configurations are listed in Appendix A.

1.4 Basic Information About Serial Communication Ports

This section provides some basic background information regarding different types of serial communication ports. Each 87/232 display contains both an RS-232 port and an RS-485 port (which is also compatible with RS-422 communication), however, *only one of the two ports can be used at any given time to communicate with a host device.*

RS-232 ports are the most common type of serial ports, although they are more common in an office environment than an industrial environment. This is because RS-232 can only be run for short distances (under 50 feet), and in environments where EMI (electromagnetic interference) is minimal. Also, one host RS-232 port is normally limited to directly communicating with one device. Every 87/232 display has a built in data converter that overcomes this limitation.

RS-422 ports are very common in industrial environments. They are well suited for distances up to 4000 feet, and have substantially superior EMI immunity characteristics. Additionally, one host RS-422 port can communicate with a minimum of 10 devices without repeating the signal.

RS-485 ports are basically an improved version of RS-422, and in most cases are completely compatible with RS-422 devices (and vice versa). In fact, many newer products with built in RS-422 ports actually use driver circuits that meet the RS-485 specification (87 series displays fall into this class). RS-485 offers better EMI immunity characteristics, and improved drivers that have the ability to communicate with up to 32 devices without repeating the signal. There is sometimes confusion regarding RS-485 because it has an additional ability to communicate in both directions over one pair of wires, a feature not supported by RS-422 or by 87 series displays.

20 mA current loop was commonly used for industrial applications in the past but is less common today. To use a 20mA current loop serial port with an 87/232 display, all that is required is an external 20 mA current loop to RS-422 converter. Vorne can provide such a converter if your application requires it.

1.5 RS-232 Communication To A Single Display

This section provides the information necessary to successfully interface a host RS-232 port to one 87/232 display. If you would like to interface a host RS-232 port to multiple 87/232 displays, read this section as well as sections 1.6 and 1.7.

Selecting RS-232 Communication

A printed circuit board mounted COM PORT slide switch, located approximately one inch below the COM PORT terminal strip, is used to select between RS-232 and RS-422/RS-485 communication. Set this switch to the **RS-232** position.

RS-232 Connectors

The RS-232 port is fully opto-isolated and is available on pins 3 to 5 of the 9 pin communication port terminal strip (marked P2). The RS-232 portion of this terminal strip is shown below.

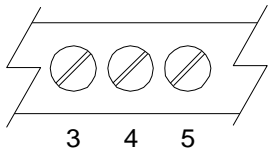
9 Pin COM PORT Terminal Strip (P2)	Pin	Function
Pins 3 to 5 RS-232 Port 	3	RS-232 Transmit Data (TxD)
	4	RS-232 Receive Data (RxD)
	5	Isolated Communication GROUND

Many host devices use either DB25 or DB9 connectors for their RS-232 ports. For your reference, two common RS-232 DB interfaces are shown below. They are the standard male DB25 interface, and the standard male IBM/AT® style DB9 interface.

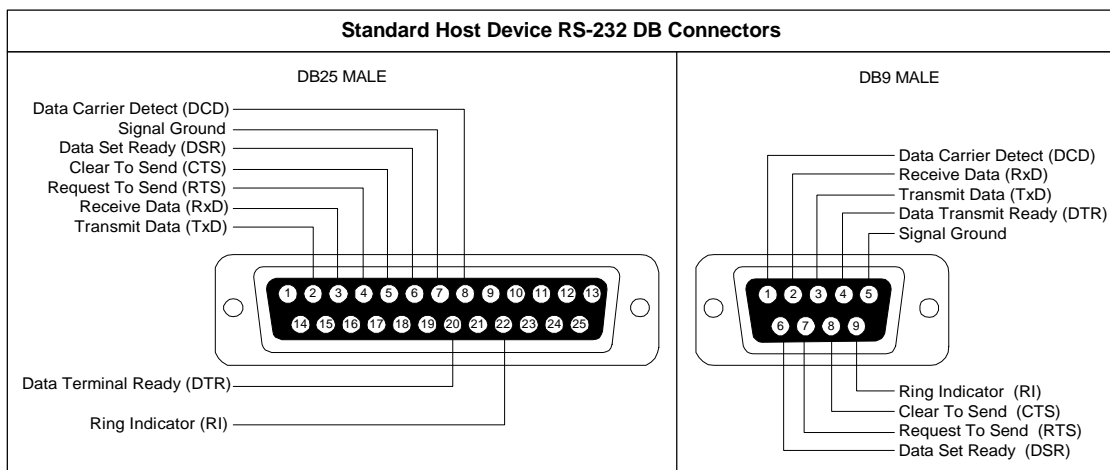

Wiring Diagram For An RS-232 Host Device To One Display

The only connections necessary for two way communication between a host device and an 87/232 display are the ones shown in the diagram below. Please refer to the Guidelines For Wiring RS-232 Devices section below for important wiring recommendations. For one way communication from the host to the display, the transmit data (TxD) line from the display (pin 3) does not need to be connected to the host device.

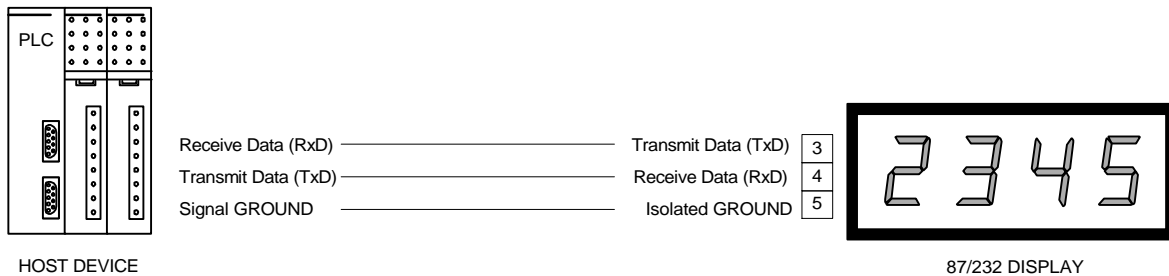

Guidelines For Wiring RS-232 Devices

For best results when wiring RS-232 devices please follow these guidelines:

1. Use a 50 foot maximum cable length.
2. Use a baud rate of 19,200 or less.
3. Use a shielded cable with the shield connected to Earth Ground *only at the 87/232 display*. Belden 9842 is a recommended cable.
4. Carefully check your equipment and cable to ensure that Earth Ground is *not* connected at both ends of the cable. If there is a significant difference in Earth Ground potential between the two ends of the cable, it could cause data transmission errors, or even damage to the RS-232 communication ports.
5. Keep the cable length as short as possible, and do not run the RS-232 cable parallel to any power cables.

1.6 RS-422 Or RS-485 Communication To One Or More Displays

This section provides the information necessary to successfully interface a host RS-422 or RS-485 port to one or more 87/232 displays. Note that the 87/232 display contains an opto-isolated RS-485 port which is also fully compatible with RS-422 host devices.

Selecting RS-422/RS-485 Communication

A printed circuit board mounted COM PORT slide switch, located approximately one inch below the COM PORT terminal strip, is used to select between RS-232 and RS-422/RS-485 communication. Set this switch to the **RS-485** position.

RS-422/RS-485 Connectors

The RS-422/RS-485 port is fully opto-isolated and is available through the last five pins of the nine pin communication port terminal strip (marked P2). The RS-422/RS-485 portion of this terminal strip is shown below.

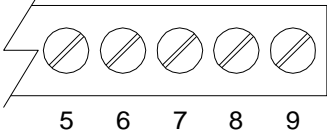
9 Pin COM PORT Terminal Strip (P2)		Pin	Function
Pins 5 to 9		RS-422/RS-485 Port	
		5	Isolated Communication GROUND
		6	RS-422/RS-485 Transmit Data (TxD) +
		7	RS-422/RS-485 Transmit Data (TxD) -
		8	RS-422/RS-485 Receive Data (RxD) +
		9	RS-422/RS-485 Receive Data (RxD) -

Wiring Diagram For An RS-422 Or RS-485 Host Device To One Display

Below is a diagram which shows how to wire an RS-422 (or RS-485) host device to one display. Please refer to the Guidelines For Wiring RS-422 Or RS-485 Devices section below for important wiring recommendations, and take special note of the four terminating resistors shown in the diagram below. For one way communication from the host to the display, the transmit data (TxD) lines from the display (pins 6 and 7) do not need to be connected.

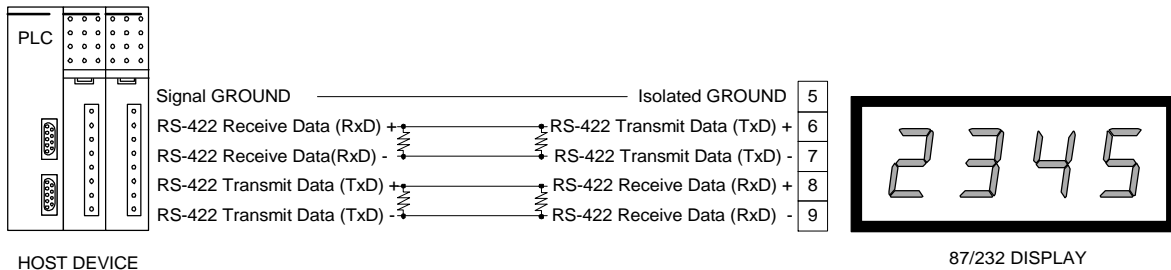

Wiring Diagram For An RS-422 Or RS-485 Host Device To More Than One Display

Below is a diagram which shows how to wire an RS-422 (or RS-485) host device to multiple displays. Please refer to the Guidelines For Wiring RS-422 Or RS-485 Devices section below for important wiring recommendations, and take special note of the four terminating resistors shown in the diagram below.

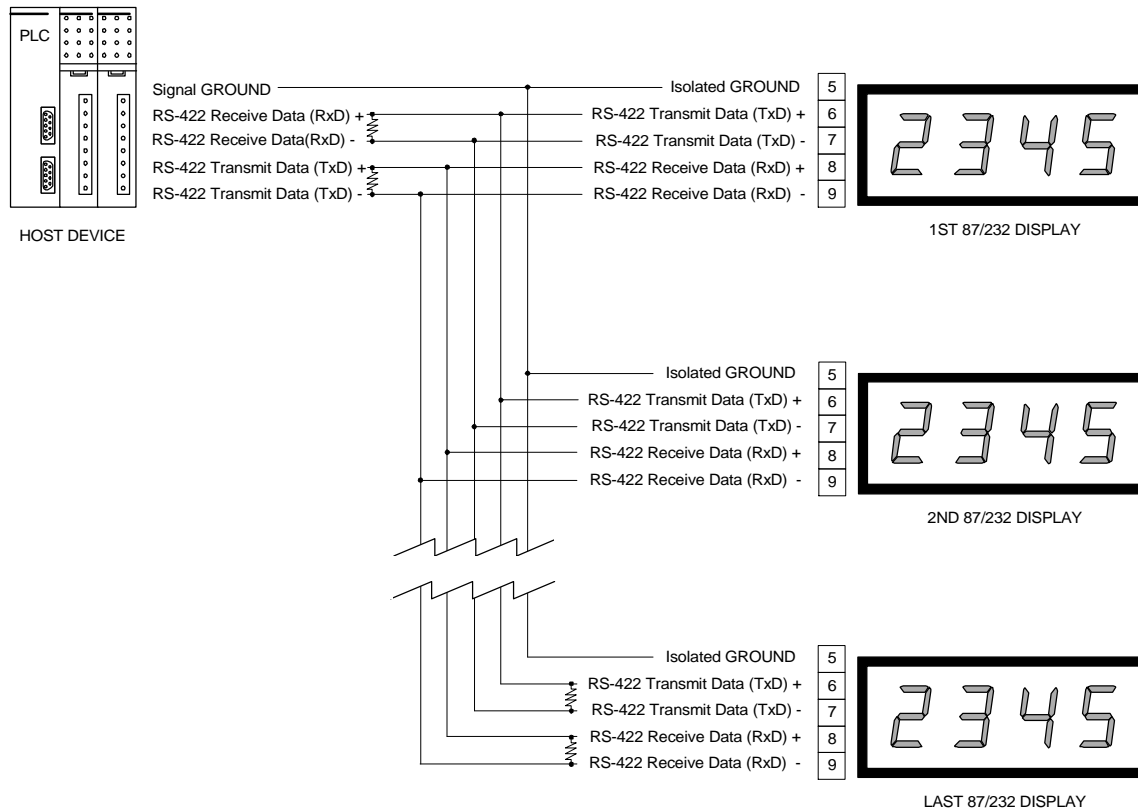

Guidelines For Wiring RS-422 Or RS-485 Devices

For best results when wiring RS-422 or RS-485 devices please follow these guidelines:

1. Use a 4,000 foot maximum total cable length.
2. Use a maximum of 10 displays connected to one RS-422 host port, or 32 displays connected to one RS-485 host port unless your host device specifies a higher number.
3. Use a shielded cable with the shield connected to Earth Ground *only at the 87/232 display*. Belden 9843 is a recommended cable.
4. Carefully check your equipment and cable to ensure that Earth Ground is *not* connected at both ends of the cable. If there is a significant difference in Earth Ground potential between the two ends of the cable, it could cause data transmission errors, or even damage to the RS-422 or RS-485 communication ports.

5. Terminate the cables. *In all RS-422 and RS-485 installations, the cable must be correctly terminated with two sets of resistors, one set at each end of the network. This applies even if you are only using one display connected to one host device.* The terminating resistors prevent reflection problems that can interfere with data transmission. The resistance value of the terminating resistors should match the characteristic impedance of the cable. A typical value is 120 ohms. The terminating resistors must be placed at the two farthest ends of the RS-422 or RS-485 network, regardless of where the host device is. In some cases host device RS-422 and RS-485 ports have built in or optional terminating resistors. Take care to check that your network (whether it has one display or 32 displays) has only two sets of terminating resistors.
6. In applications with multiple displays, bring the communication wiring point to point. In other words do not run stubs from the "backbone" network wiring to each display. If you find it absolutely necessary to run a stub from the backbone network wiring, make sure it is under one foot in length.

1.7 RS-232 Communication To More Than One Display

87/232 displays have a built in data converter that can be used to convert host device RS-232 data to RS-485 data and vice versa. This allows the host device to communicate via RS-232 to one 87/232 display (called the **converting display**), which will retransmit any RS-232 data received from the host device as RS-485 data to all other displays in the network. Likewise, any RS-485 data received by the converting display from other displays in the network will be retransmitted out its RS-232 port to the host device.

To wire a network of displays that can be communicated to from one host device RS-232 port, follow these steps:

Step 1: Wire your host device RS-232 port to the first display's RS-232 port as described in Section 1.5 RS-232 Communication To A Single Display. This display will be the converting display. Make sure to set the COM PORT slide switch to the **RS-232** position *only* for the converting display. All other displays in the network should have the COM PORT slide switch set to the **RS-485** position.

Step 2: Use the converting display's RS-485 port to connect to other displays in the network as described in Section 1.6 RS-422 Or RS-485 Communication To One Or More Displays. Where RxD+ of the converting display is connected to RxD+ of the other displays in the network and RxD- of the converting display is connected to RxD- of the other displays in the network.

1.8 Understanding The General Display Format

The default display format is right justified, leading zeroes blanked and no fixed decimal point. These settings can be changed with *VDP4*. *VDP4* is a Windows™ based utility that allows customization of the 87/232 display. See Chapter 4 for additional details.

Chapter 2 Using Terminator Only Protocol

This chapter describes the communication protocol of **Terminator Only**. This is for applications where you can control the data being transmitted to the display, and wish to use the very simplest form of communication possible.

2.1 Terminator Only Protocol Communication Format

The format of **Terminator Only** communication is:

Data Terminator

Data Any ASCII characters you wish to display (refer to Appendix B for a full character set listing).

Terminator A special ASCII character which marks the end of the data (and thus immediately follows it). The terminator character is a dip switch setting. Note that the symbol **<CR>** represents the ASCII "Carriage Return" character (0D hex/13 decimal), and the symbol **<LF>** represents the ASCII "Line Feed" character (0A hex/10 decimal). In cases where the host device transmits a **<CR><LF>** combination as the terminator, select **<CR>**.

Examples

The following examples assume that the default Terminator of **<CR>** is selected.

To Show On The Display...	Transmit
1234	1234<CR>
888.8	888.8<CR>

Chapter 3 Using The Simple Packet Protocol

This chapter describes the communication protocol of **Simple Packet**. This is for applications where you can control the data being transmitted to the display, but where you would like to access advanced features. These features include independently addressing multiple displays, flashing the display, or controlling an optional relay in the display.

3.1 Simple Packet Communication Format

The format of **Simple Packet** communication is:

<SOH> Type Address : Command Data Terminator Checksum

<SOH> The symbol **<SOH>** represents the ASCII "Start Of Header" character (01 hex/1 decimal), and must be the first character of every transmission. Since the purpose of the **<SOH>** character is to mark the beginning of a new packet, it cannot appear anywhere else within the transmission.

Type Can be one of two ASCII characters (**S** or **s**), and must be the second character of every transmission. This character lets the display know if the serial data is meant for an individual address or a group address.

S Serial data for an individual address.

s Serial data for a group address.

If your application does not require addressing individual displays or groups of displays, you should use the type **s**. This will allow data that you send to be acted upon by every display that receives it (as explained below).

Address Can range from **0** to **255**, and is an optional part of the packet that specifies an actual unit or group address. If no address is included in the packet, the default address of **0** will be used. Addresses 0 to 14 are selectable using the internal DIP switch. Setting a unit to addresses 15 to 255 requires VDP4.

Note that a transmitted *group* address of **0** is a broadcast to all units, regardless of what the internal address of each display is set to. Thus, when no addressing is required, you can skip the **Address** part of the packet, and rely on the fact that a default address of 0 will automatically be substituted. In this case, the complete header before the data would be **<SOH>s:** and the data will be acted on by all displays that receive it.

For more information about individual and group addressing see Section 3.3 Addressing Multiple Displays.

: The ASCII "Colon" character (3A hex/58 decimal) must be included in every transmission, and is used to separate the header part of the packet from the data.

Command Can contain one command string for the display. Command strings can be used to display data, set the clock, flash data on the display, or control the optional relay. The available commands are fully described in Section 3.2 Simple Packet Commands.

Data Any ASCII characters you wish to display (refer to Appendix B for a full character set listing). The control characters **<SOH>**, **<CR>** and **<LF>** cannot be used in the **Data** part of the packet, as they are reserved for marking the beginning and end of packets.

Terminator A special ASCII character which marks the end of the data (and thus immediately follows it). The Terminator character is a DIP switch selection. Note that the symbol <CR> represents the ASCII "Carriage Return" character (0D hex/13 decimal), and the symbol <LF> represents the ASCII "Line Feed" character (0A hex/10 decimal). In cases where the host device transmits a <CR><LF> combination as the terminator, select <CR>.

Checksum This is an optional part of the packet that can be used to provide an extra level of data validation. If used, the checksum immediately follows the Terminator character. Please request the Advanced Applications Guide if you are interested in using a checksum.

3.2 Simple Packet Commands

The command portion of the packet can contain one (and only one) command string for the display. Command strings can be used to display data, set the clock, flash data on the display, change display color on tri-color displays, or control the optional relay. Each of these commands is fully described below.

To accomplish more than one command (e.g. flash data on the display and turn the relay on), you must send a separate packet for each command.

Remember that the control characters <SOH>, <CR> and <LF> cannot be used anywhere in the data portion of the packet, as they are reserved for marking the beginning and end of packets.

Display Data

Data to be displayed is preceded by the ASCII character **D** (44 hex/68 decimal). Note that the **D** must be upper case. The data will be displayed in a fixed (non-flashing) manner.

The following examples assume that addressing is not being used, and that Terminator has been selected as <CR>. Also note that the header of the packet <SOH>s: has the effect of broadcasting to all displays, overriding any group or individual address a display might be set to.

To Show On The Display...	Transmit
1234	<SOH>s:D1234<CR>
888.8	<SOH>s:D888.8<CR>

Flash Data

Data to be displayed flashing is preceded by the ASCII character **F** (46 hex/70 decimal). Note that the **F** must be upper case. The data will be displayed flashing.

The following examples assume that addressing is not being used, and that Terminator has been selected as <CR>. Also note that the header of the packet <SOH>s: has the effect of broadcasting to all displays, overriding any group or individual address a display might be set to.

To Flash On The Display ...	Transmit
1234	<SOH>s:F1234<CR>
888.8	<SOH>s:F888.8<CR>

Change Color (For Tri-color Display's)

Some 87 series displays are available with a tri-color display option. With the tri-color option, each digit color can be individually set to red, yellow or green.

The **Color** command string begins with the ASCII character **C** (43 hex/67 decimal). Note that the **C** must be upper case. The rest of the data consists of a string of upper case ASCII characters which represent the color each digit of the display should be set to, starting with the most significant (left most) digit. The available colors are:

<u>Color</u>	<u>ASCII Character</u>	<u>Hex/Decimal Representation</u>
Red	R	52 hex/82 decimal
Yellow	Y	59 hex/89 decimal
Green	G	47 hex/71 decimal

If the **C** command is sent with only one color character (for example **CR**), the entire display will be set to that color. The **Color** command takes effect as soon as it is received.

The following examples assume that addressing and checksums are not being used, and that Terminator has been selected as <CR>. Also note that the header of the packet <SOH>s: has the effect of broadcasting to all displays, overriding any group or individual address a display might be set to.

To Set The Display Color To...	Transmit
All Yellow	<SOH>s:CY<CR>
2 Digits Red, 2 Digits Green	<SOH>s:CRRGG<CR>

Activate Relay

An optional relay output board can be added to the 87/232 display, to be used for additional annunciation.

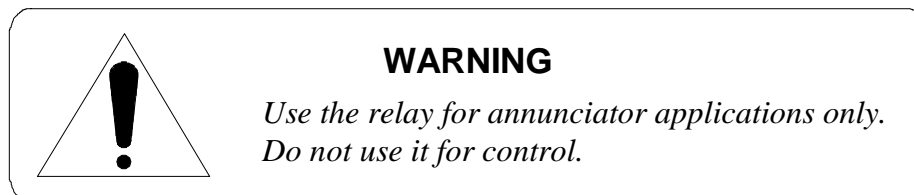

The **Relay** command string begins with the ASCII character **R** (52 hex/82 decimal). Note that the **R** must be upper case, and must be followed by one character (which determines what relay action will occur). The available actions are:

<u>Action</u>	<u>ASCII Character</u>	<u>Hex/Decimal Representation</u>
Turn relay on	1	31 hex/49 decimal
Turn relay off	0	30 hex/48 decimal
Sequence A	A	41 hex/65 decimal

Sequence A is a user definable relay sequence (e.g. cycle the relay 20 times with each cycle consisting of 1.0 second on and 2.0 seconds off), which can be triggered with one command. For more information about the user definable relay sequence, please refer to Chapter 4 Advanced Features Of The 87/232 Display.

The following examples assume that addressing and checksums are not being used, and that Terminator has been selected as <CR>. Also note that the header of the packet <SOH>s: has the effect of broadcasting to all displays, overriding any group or individual address a display might be set to.

To....	Transmit
Turn the relay on	<SOH>s:R1<CR>
Turn the relay off	<SOH>s:R0<CR>
Trigger Sequence A	<SOH>s:RA<CR>

3.3 Addressing Multiple Displays

Using an RS-422 or RS-485 network (described in Section 1.6 RS-422 Or RS-485 Communication To One Or More Displays) together with addressing allows a host computer or PLC to communicate with specific individual displays or groups of displays in a network. Each display in the network may be assigned a unit address *and* a group address. If you do not need to address individual displays, or groups of displays, simply leave the display set to the default setting of Terminator only (DIP switches 7, 8, 9 and 10 ON), and skip this section.

Unit Address

Unit Address is a DIP switch selection that allows you to select an individual unit address. Individual unit addresses can range from **0** to **255**, allowing up to 256 displays to be individually addressed in a network. Using the DIP switch, up to 15 addresses (0 to 14) can be selected.

If a packet is directed to a specific unit address, only units set to that address will respond to the data. More than one display may use the same unit address. Remember, if the data in the packet is meant for a specific unit address, the serial data type **S** must follow the <SOH> character in the transmission packet (as shown in the examples below).

The following examples assume that **Unit Address** is set to **10**, checksums are not being used, and that **Terminator** has been selected as **<CR>**. Also note that an upper case **S** follows the **<SOH>** indicating that the serial data is intended for an individual display address, and the **D** command character is being used to display data.

To Show Only On Displays With A Unit Address Of 10...	Transmit
1234	<SOH>S10:D1234<CR>
888.8	<SOH>S10:D888.8<CR>

3.4 Using Checksums And Command Acknowledgments

Using checksums and command acknowledgments can improve the reliability of data transfer between the host device and the display. They are optional features of the simple packet protocol - either or both can be used.

Checksums allow the display to check if data has become corrupted during transmission from the host device to the display. Command acknowledgments are used to let the host device know if data received by the display can be acted upon (i.e. the data is valid for the command transmitted, and the command and data are appropriate for the particular display). If checksums are being used, command acknowledgments also provide a means of letting the host device know that the data was received with a proper checksum.

If you are interested in using checksums and/or command acknowledgment to improve data transfer reliability, please request the Advanced Applications Guide.

Chapter 4 Advanced Features Of the 87/232 Display

The 87/232 has been designed in such a way that it can be customized to meet a users specific requirements. The unit is shipped from the factory set to DIP switch settings. The DIP switch settings allow the user to select the baud rate (300, 1200, 9600, or 19200), number of data bits (7 or 8), line terminator (<CR> or <LF>), and Unit Address (0 to 14 or Terminator Only). The DIP switch settings have been selected so that a majority of users can setup the display with minimal effort.

Additional settings such as right justified data, leading zeroes blanked, and no fixed decimal point are programmed at the factory and are not DIP switch selectable. Applications that do not fit the DIP switch settings can be accommodated by using VDP4 to customize the operation of the 87/232 display. *VDP4* is a WindowsTM based utility that is available from Vorne. To bypass the DIP switch settings, DIP switch 2 should be set to VDP4 (off). Setting the unit to VDP4 settings allows the unit to operate with the settings that are stored in a EEPROM on the displays logic board.

For additional information on topics discussed in this chapter, request the *Advanced Applications Guide*.

4.1 VDP4 Options

The following is a list of 87/232 options that can be programmed using VDP4.

Baud Rate

Available selections are 300, 600, 1200, 2400, 4800, 9600, 19200, or 57600.

Data Bits

Available selections are 7 or 8.

Display Justification

Available selections are Left or Right Justify.

Leading Zeroes

Available selections are Do Not Blank or Blank leading zeroes.

Fixed Decimal Point After Digit

Available selections are None, 1, 2, 3, 4, 5, 6, 7, or 8.

Number of Display Digits

Available selections are 2, 3, 4, 6, or 8.

Header

The header is used by the display to identify the beginning of a matching data stream. This parameter is only available in Universal Protocol mode, and is limited to 16 characters.

Terminator

The Terminator selection specifies which character ends the transmission. Available selections are <CR> or <LF>. Additional selections are available in Universal Protocol mode.

Checksum

This is an optional part of the packet that can be used to provide an extra level of data validation. If used, the checksum immediately follows the Terminator character.

Command Acknowledgment

Command acknowledgments are used to let the host device know if data received by the display can be acted upon (i.e. the data is valid for the command transmitted, and the command and data are appropriate for the particular display). If checksums are being used, command acknowledgments also provide a means of letting the host device know that the data was received with a proper checksum.

Unit Address

Unit Address allows you to select an individual unit address. Individual unit addresses can range from **0** to **255**, allowing up to 256 displays to be individually addressed in a network.

Member of Group(s)

Member of Group(s) allows you to select any combination of up to eight display groups that the display can belong to. A packet addressed to a specific group or combination of groups will only be acted on by displays belonging to the group(s). Available selections are 1 to 8.

Relay Setup

Relay Sequence A is user definable as either a Delay On Relay or Cycle Relay. The Delay On Relay selection allows adjustment of the delay and duration time. These settings are adjustable from .1 to 25.5 seconds. The Cycle Relay selection allows specifying the ON time (.1 to 25.5 seconds), OFF time (.1 to 25.5 seconds), and number of cycles to perform (adjustable from 1 to 255 times).

Selecting A Communication Protocol

The **communication protocol** is a very important selection, as it determines the basic manner in which you will be communicating to the display. Different types of applications lend themselves naturally to different communication protocols. We have divided typical applications into four groups, each with its own communication protocol. This section gives guidance in which communication protocol will best suit your application.

Terminator Only: This is for applications where you can control the data being transmitted to the display, and wish to use the very simplest form of communication possible.

Terminator Only protocol is available by setting the address DIP switch to Terminator Only (switches 7, 8, 9 and 10 ON).

Simple Packet: This protocol is for applications where you can control the data being transmitted to the display, but where you would like to access advanced features. These features include independently addressing multiple displays, flashing the display, or controlling an optional relay in the display. Simple Packet protocol is available by setting the address DIP switch to settings 0 to 14. VDP4 allows defining addresses 0 to 255.

This protocol can also be used for applications where you simply want to connect one or more 87/232 displays to a keypad, and display whatever you type in. It is also used for clock applications where the time is to be periodically set from a keypad. Vorne manufactures a low cost and simple to operate hand held terminal for Keypad applications called the Mini-T. Or, if you prefer, you can use our free Windows™ software utility *87 Express*, to read or set values right from your PC. If after reviewing the remainder of this section, this seems to be the best communication protocol for your application, please request the Advanced Applications Guide.

Universal protocol. This is for applications where you have limited or no control of the data being transmitted to the display, and would like the display to intelligently process incoming data and select a portion of it to be displayed. Example applications include interfacing to scales, clock systems, panel meters, or any other device where the data stream has already been defined. If after reviewing the remainder of this section, this seems to be the best communication protocol for your application, please request the Advanced Applications Guide.

77 Series protocol. This is for applications where you want to connect 87/232 displays to the same communication bus as 77/232 displays (an earlier Vorne product line), or where you want to use existing software drivers written for 77/232 displays. If this seems to be the best communication protocol for your application, please request the Advanced Applications Guide. Note that for new applications we recommend using the Simple Packet protocol described in Chapter 3 instead of the 77 Series protocol, as it is a more flexible and robust protocol, and is supported by other Vorne products (such as the 2100 series of panel mount alphanumeric displays).

Appendix A Operating Specifications

LED Life 100,000 hours typical

Serial Input RS-232, RS-485

Optional Relay Output

Single Pole Double Throw
Rated 120VAC @ 1A

Power Supply

120 VAC +/- 15% (50 - 60 Hz)
12 VDC +/- 5%

Power Requirements

All power requirements in the following table are listed in VA (Volt Amps).

Digit Type	Red Or Yellow Display				
	2 Digit	3 Digit	4 Digit	6 Digit	8 Digit
4" Discrete Segment	NA	6.62	8.3	11.65	15
4" Solid Segment	NA	13.25	16.6	23.3	30
6" Discrete Segment	9.9	13.25	16.6	23.3	30
8" Discrete Segment	14.84	19.87	24.9	34.95	45.01
12" Discrete Segment	19.79	26.49	33.2	46.6	60.01

For Green Displays, multiply the current value in the table by 1.25.
For Tri-Color Displays, multiply the current value in the table by 2.5.

















































































Temperature Range

Operating 32 to 122 degrees F (0 to 50 degrees C)

Humidity 5% to 95% non-condensing

Appendix B Character Set Listing

This table lists the full 87/232 character set in a standard ASCII format. As a primarily numeric, seven segment display, many non-numeric characters can be displayed in only a limited fashion. The hex and decimal ASCII codes are shown for each character. The upper and lower case alpha character sets are identical. They are designed to be as readable as possible, within the constraints of a seven segment display. If a character is not listed it will be displayed as blank (as will all characters 20h and below).

20h 32d	21h 33d		22h 34d		23h 35d	24h 36d	25h 37d	26h 38d	27h 39d						
28h 40d		29h 41d		2Ah 42d	2Bh 43d	2Ch 44d		2Dh 45d		2Eh 46d		2Fh 47d			
30h 48d		31h 49d		32h 50d		33h 51d		34h 52d		35h 53d		36h 54d		37h 55d	
38h 56d		39h 57d		3Ah 58d	3Bh 59d	3Ch 60d	3Dh 61d		3Eh 62d	3Fh 63d					
40h 64d		41h 65d		42h 66d		43h 67d		44h 68d		45h 69d		46h 70d		47h 71d	
48h 72d		49h 73d		4Ah 74d		4Bh 75d		4Ch 76d		4Dh 77d		4Eh 78d		4Fh 79d	
50h 80d		51h 81d		52h 82d		53h 83d		54h 84d		55h 85d		56h 86d		57h 87d	
58h 88d		59h 89d		5Ah 90d		5Bh 91d		5Ch 92d	5Dh 93d		5Eh 94d		5Fh 95d		
60h 96d		61h 97d		62h 98d		63h 99d		64h 100d		65h 101d		66h 102d		67h 103d	
68h 104d		69h 105d		6Ah 106d		6Bh 107d		6Ch 108d		6Dh 109d		6Eh 110d		6Fh 111d	
70h 112d		71h 113d		72h 114d		73h 115d		74h 116d		75h 117d		76h 118d		77h 119d	
78h 120d		79h 121d		7Ah 122d		7Bh 123d		7Ch 124d		7Dh 125d		7Eh 126d	7Fh 127d		

Appendix C Display Dimensions

The 87 Series display was designed to be suspended from a pair of chains. Make sure that the supporting chain can support the weight of the display. Failure to follow this warning could result in damage to property, or personal injury.

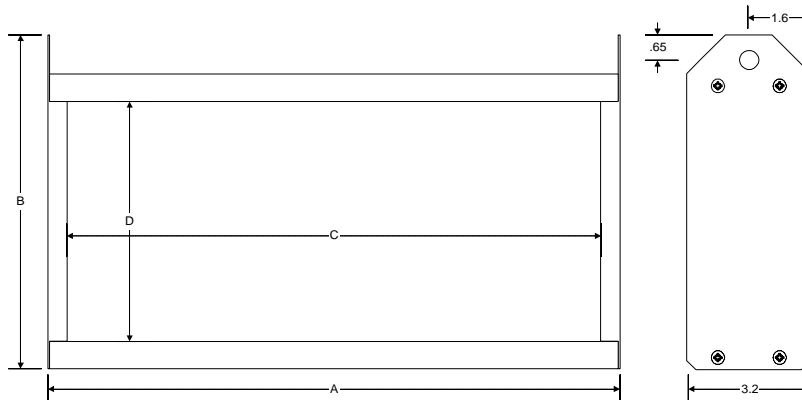

	A	B	C	D
4" Display 3 Digit	12.75	8.40	11.75	5.70
4" Display 4 Digit	16.30	8.40	15.30	5.70
4" Display 6 Digit	23.40	8.40	22.40	5.70
4" Display 8 Digit	30.50	8.40	29.50	5.70
4" Display 12 Digit	44.70	8.40	43.70	5.70
4" Display 16 Digit	58.90	8.40	57.90	5.70
4" Display 20 Digit	73.10	8.40	72.10	5.70
6" Display 2 Digit	12.90	10.40	11.90	7.70
6" Display 3 Digit	18.30	10.40	17.30	7.70
6" Display 4 Digit	23.70	10.40	22.70	7.70
6" Display 6 Digit	34.50	10.40	33.50	7.70
6" Display 8 Digit	45.30	10.40	44.30	7.70
8" Display 2 Digit	15.90	12.40	14.90	9.70
8" Display 3 Digit	22.80	12.40	21.80	9.70
8" Display 4 Digit	29.70	12.40	28.70	9.70
8" Display 6 Digit	43.50	12.40	42.50	9.70
8" Display 8 Digit	57.30	12.40	56.30	9.70
12" Display 2 Digit	22.80	16.40	21.80	13.70
12" Display 3 Digit	33.15	16.40	32.15	13.70
12" Display 4 Digit	43.50	16.40	42.50	13.70
12" Display 6 Digit	64.20	16.40	63.20	13.70
12" Display 8 Digit	84.90	16.40	83.90	13.70

All Dimensions in inches.